

AQUASCREEN - SERIES B

THE COMPLETE RANGE OF INCLINED BAR SCREENS

Aquatec Maxcon have one of the most comprehensive ranges of bar screens in the world.

A major feature of our technology includes the range of inclined bar screens that provide a robust and reliable automated screenings removal system.

Our bar screens can be used for the removal of gross solids from water, stormwater and sewage streams. These consist of uniformly spaced bar racks with bars at 15-50mm spacing placed in open channels. Material in the flow caught on the bars is removed by an automatic screenings removal system.

AQUASCREEN SERIES B COMES IN THREE DESIGNS, EACH WITH THEIR OWN SPECIAL FEATURES

DESIGN ADVANTAGES

- Tapered bars with narrow upstream aperture capture material at the surface and reduce risk of material jamming within the screen bars.
- Screen bars are inclined at about 70° to horizontal to increase effective screening area.
- Resettable overload couplings prevent mechanical damage. Electrical indication of overload is available.
- Suitable for channels substantially below grade.
- Raking tynes contact the screen at an angle greater than 90° to lift screenings from the bars.
- Machined tynes ensure accurate tooth spacing and minimum clearance for highest possible removal efficiency.
- A range of compatible screenings conveyors, presses and turntables are available for total handling capacity.

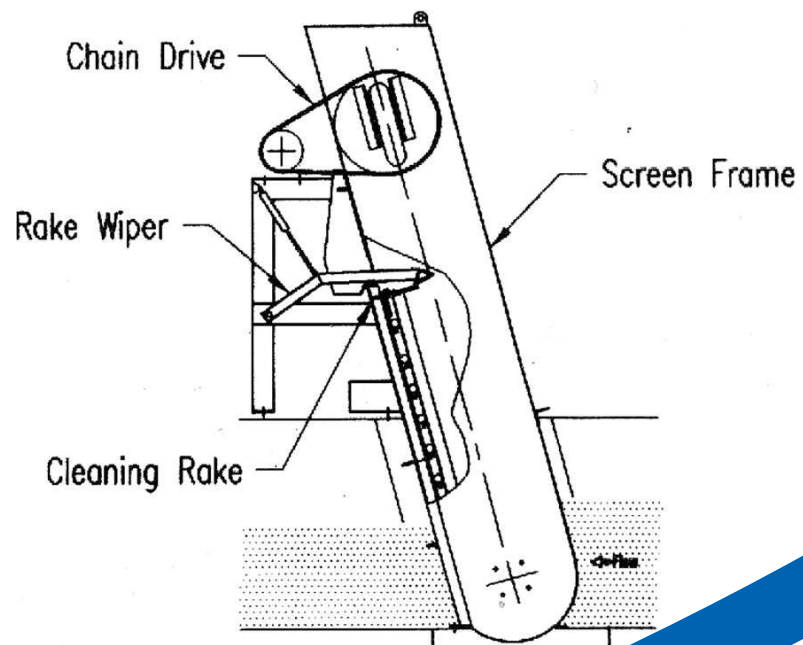
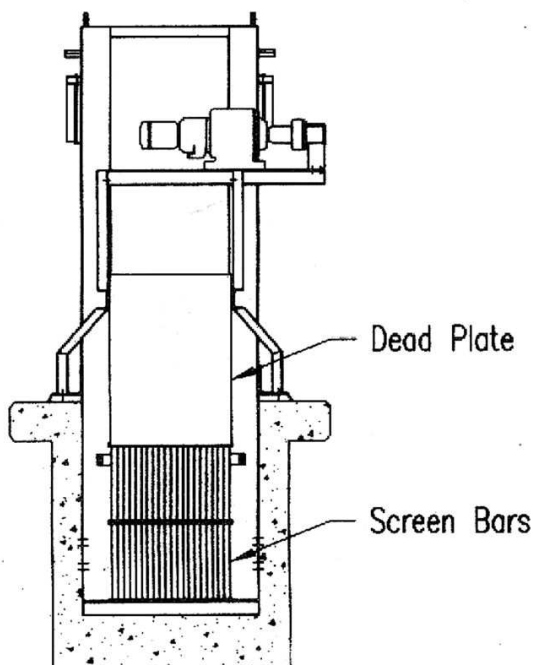

AQUASCREEN SERIES B - CT



DESIGN FEATURES

AQUASCREEN SERIES B - CT (CHAIN AND TYNE)

- Simple low cost design using continuous chains operating in replaceable stainless steel guides and carrying a series of raking combs.
- Lower sprockets run in either sealed bearings with forced lubrication or water lubricated Thordon bushes supported by stainless steel shafting.
- Used on any depth channel.

AQUASCREEN SERIES B - CL (CLIMBER)

- The climber mechanism reduces the risk of jamming and wear.
- The mechanism utilises a fixed rack engaged by the driving sprocket.
- All rotating equipment remain above water level. This is made possible by the raking trajectory being produced by guide wheels operating in a track above the channel.

AQUASCREEN SERIES B - BR (BACK RAKED)

- Accepts any objects of any size without jamming.
- Rake mechanism operates on the down stream side of the screen bars. Any object too large is just not removed.
- Can be totally enclosed making it safe for operation in public areas.
- Raking mechanism is otherwise similar to chain and tyne screens.

APPLICATIONS

- Water treatment inlet screen
- Sewage treatment inlet screen
- Waste sludge screen
- Stormwater screening
- Sewer overflow screen

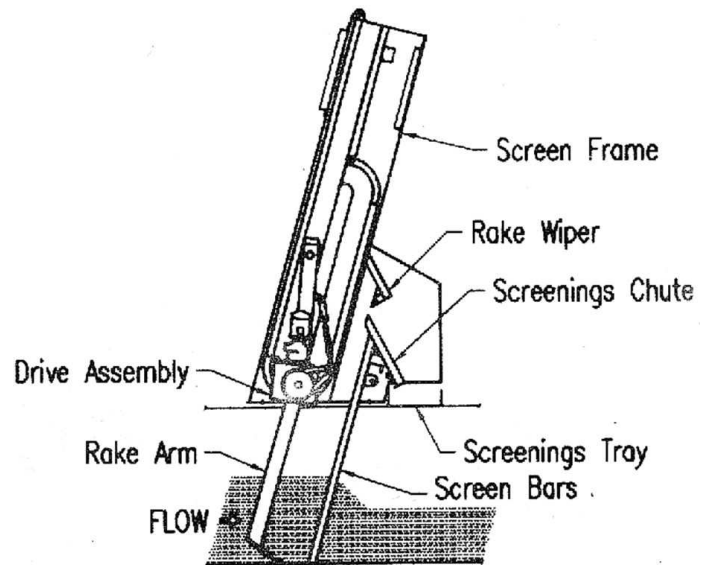

AQUASCREEN SERIES B - CL

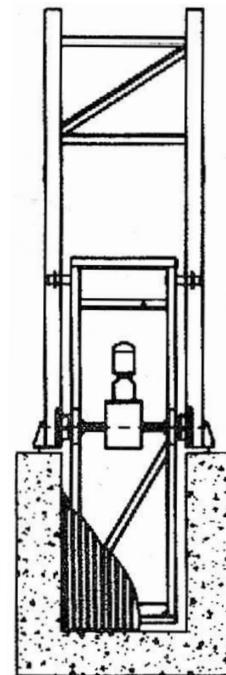



The manufacturer reserves the right to alter performance, specification or design without notice.



 Brisbane
Head Office and Factory
119 Toongarra Road
Ipswich Q 4305 AUS
P: +61 (0) 7 3813 7100
F: +61 (0) 7 3813 7199

www.aquatecmaxcon.com.au

 Sydney
Office and Factory
8 Charles Street
St Marys NSW 2760 AUS
P: +61 (0) 2 8603 5200
F: +61 (0) 2 8603 5299

 Melbourne
Office and Factory
6/64 Oakover Road
Preston VIC 3072 AUS
P: +61 (0) 3 9480 8000
F: +61 (0) 3 9480 8099

enquiry@aquatecmaxcon.com.au